

Nara

by Francesc Rifé

VICALDESIGN



Francesc Rifé

Interiorista y diseñador industrial Francesc Rifé funda su estudio en Barcelona en 1994. Influenciado por el minimalismo y marcado por una historia familiar ligada a la artesanía, articula toda su obra en torno al orden espacial y a la proporción geométrica. El trabajo interdisciplinar de su estudio incluye proyectos de interiorismo, diseño industrial, arquitectura, creación de conceptos, instalaciones, grafismo y dirección artística. Con un estilo funcionalista y minucioso, las formas y composiciones simples caracterizan su obra.

Interior designer and industrial designer, Francesc Rifé (Sant Sadurní d'Anoia, 1969) founded his studio in Barcelona in 1994. Influenced by minimalism and following a familiar tradition linked to craftsmanship, his work focuses on ways of approaching material honesty, spatial order and geometric proportion. The expansive and interdisciplinary work of his studio includes interior design projects, industrial design, architecture, concept creation, installations, graphics and art direction.

Nara es el resultado de una gran complicitad entre Vical y el estudio de Francesc Rifé. A partir del profundo respeto de ambos por la madera crece toda esta nueva familia de mobiliario caracterizada por el ritmo de sus planos paralelos.

Nara is the result of the collaboration between VICAL and Francesc Rifé's studio. This new furniture collection, rooted in both parties' deep respect for wood, is characterized by the rhythm of its parallel planes.

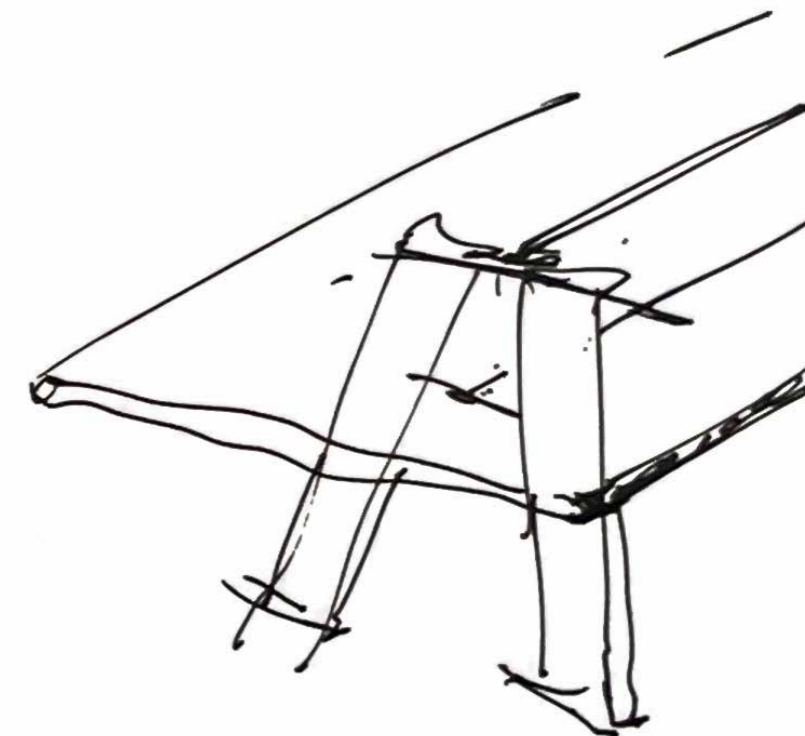
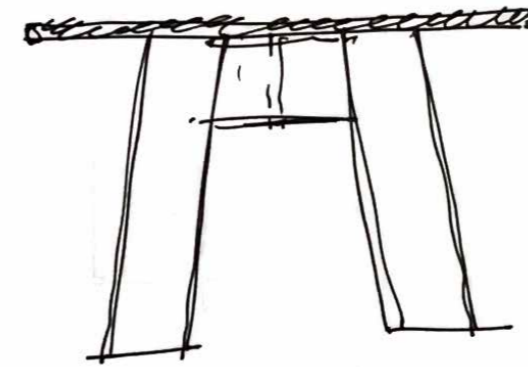
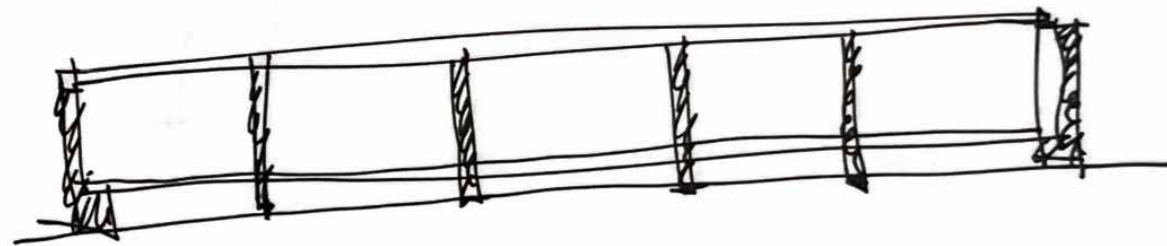
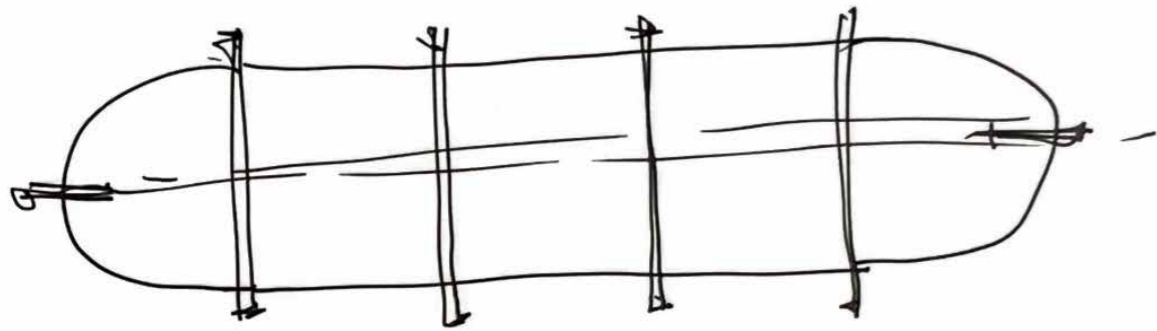
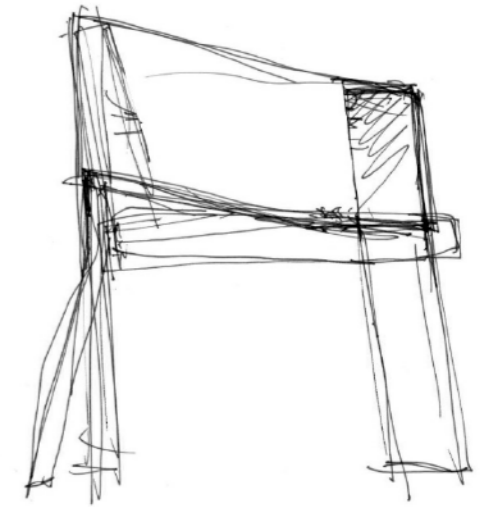
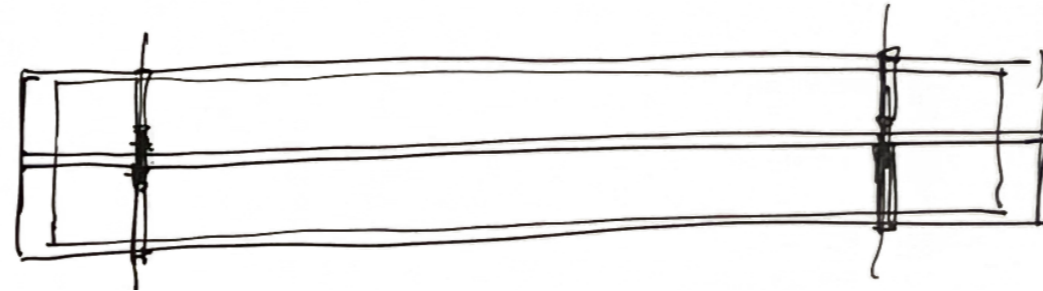



34855 240x54x25
34856 240x54x55



34855 240x54x25
34856 240x54x55



34856 240x54x55

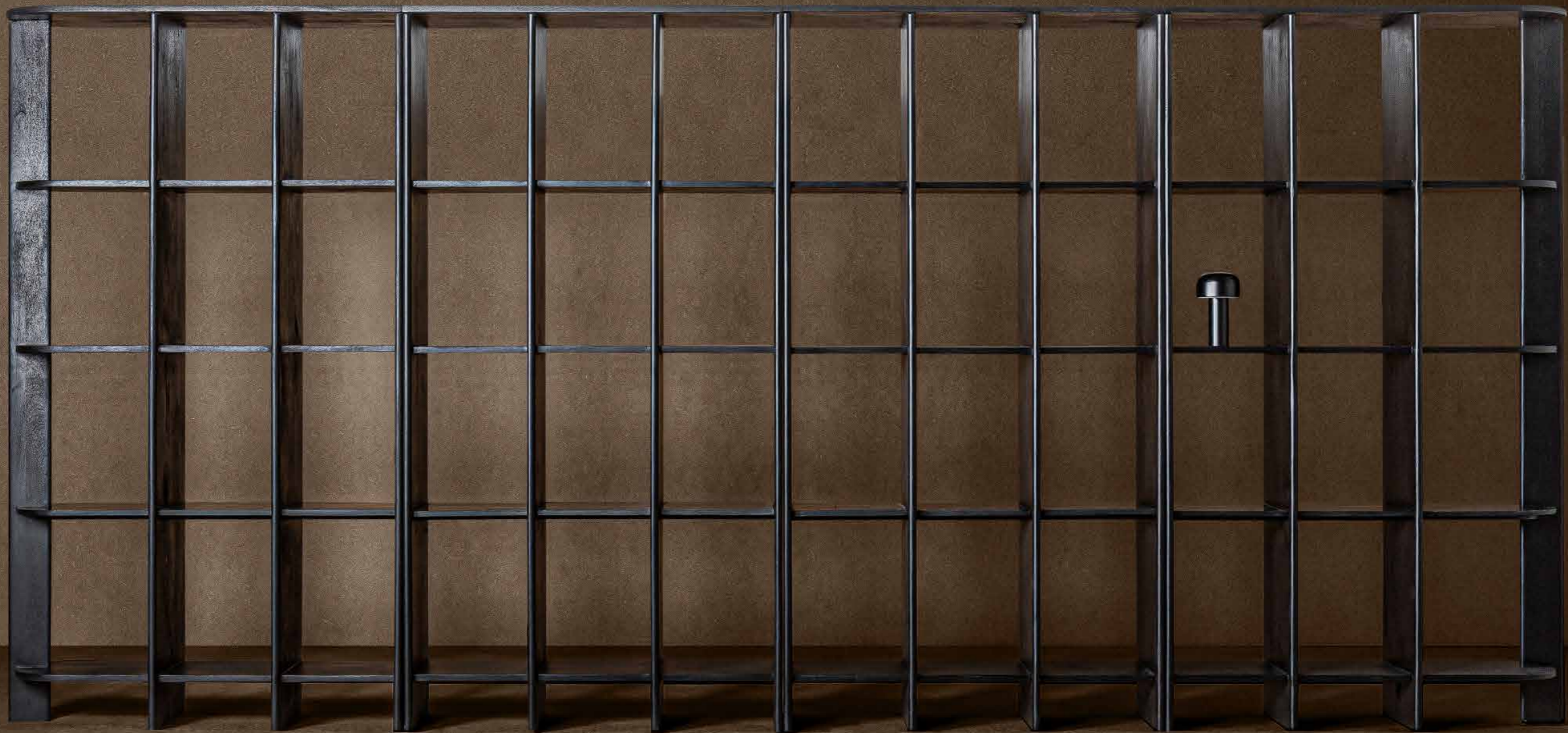

Las estanterías se organizan en composiciones rítmicas verticales con remates en semicírculo

The shelves are organized into rhythmic vertical compositions with semicircular ending.

34849 120x40x210
35927 110x40x210

SUGERENCIAS ESTANTERIAS BOOKSHELVE SUGGESTIONS

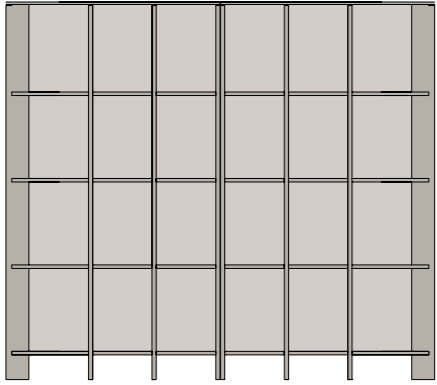

34849 + 36085
240x40x210

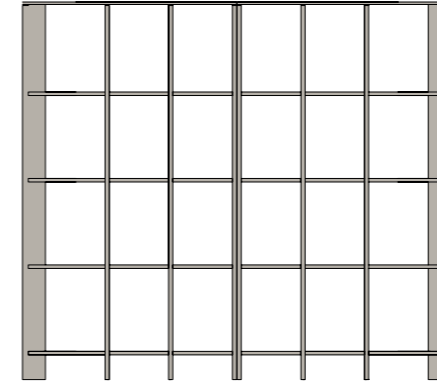

34850 + 34850
240x40x210

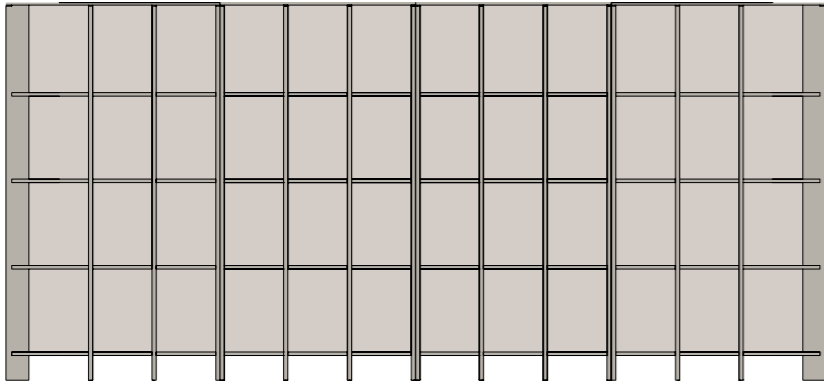

34849 + 35926 + 35926 + 36085
450x40x210

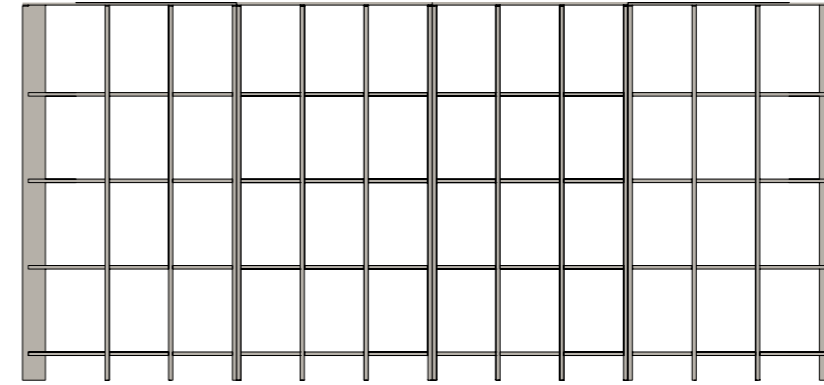

34850 + 35927 + 35927 + 34850
450x40x210

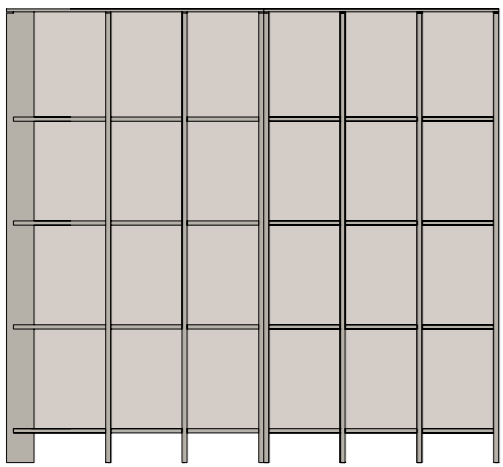

34849 + 35926
230x40x210

PARED WALL

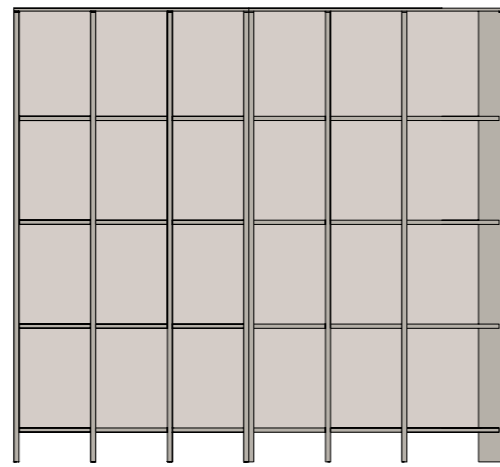

35926 + 36085
230x40x210

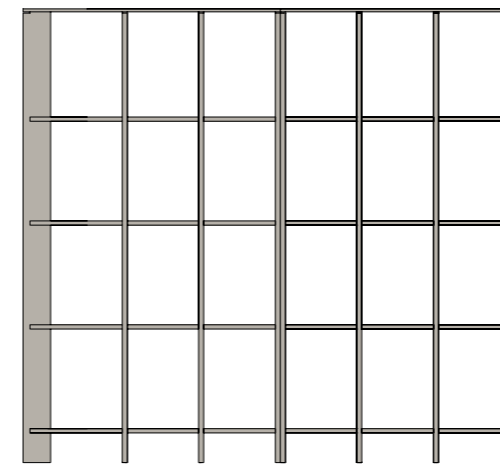

34850 + 35927
230x40x210

PARED WALL

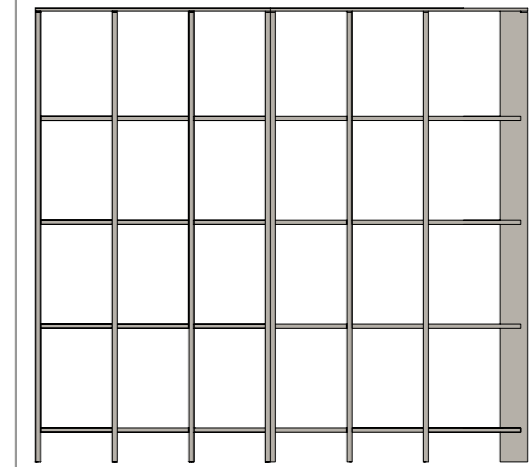

35927 + 34850
230x40x210



34858 100x100x68
34859 80x80x118



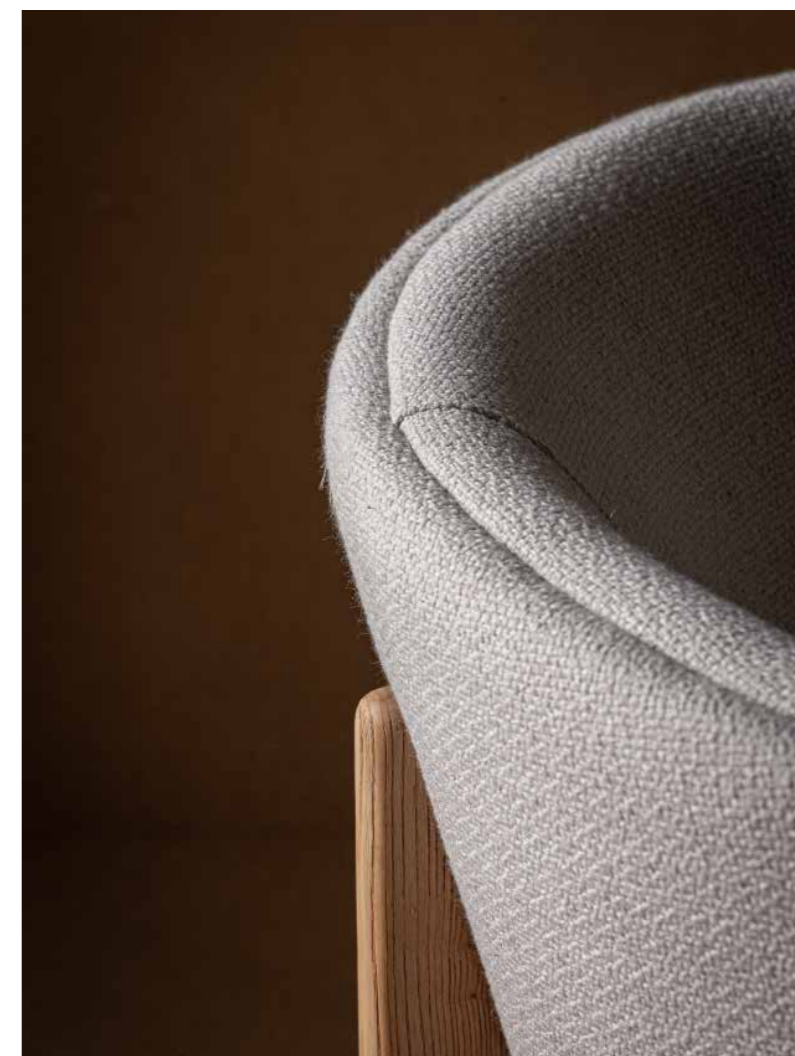

Las propuestas de asientos destacan por la combinación de las líneas amables y curvas del cuerpo con patas con una fuerte presencia, marcadas por un sutil gesto.

The seating proposals stand out for the combination of the gentle, curved lines of the body with legs that have a strong presence, marked by a subtle gesture.





34871 62x60x75
34872 62x60x75
34873 62x60x75
35057 62x60x75



34871 62x60x75
34874 69x70x69



Las mesas de comedor y de centro completan la colección con la misma narrativa en madera de roble, pero con la opción de sobre en piedra.

The dining and coffee tables complete the collection with the same oak wood narrative, but with the option of a stone top

34864 400x110x74
34870 350x45x46
35057 62x60x75



34865 150x150x75
34871 62x60x75



34867 100x100x34
34875 69x70x69





34876 90x100x82





34877 90x100x82
34879 250x105x82
34867 100x100x34



34879 250x105x82
34878 200x105x82



ESTANTERÍAS BOOKSHELVES



34849
120x40x210



35926
110x40x210



36085
120x40x210



34851
235x100x85



34849
120x40x210



35927
110x40x210



34851
235x100x85



34859
80x80x118



34857
80x80x68



34858
100x100x68

APARADORES & MUEBLES TV SIDEBORDS & TV STANDS



34854
240x54x80



34856
240x54x55



34855
240x54x25

MESAS & BANCOS TABLES & BENCHES



34863
280x105x74



34864
400x110x74



34865
150x150x74



34866
160x70x34



34867
100x100x34



34869
210x45x46



34870
350x45x46

SILLAS CHAIRS



34871
62x60x75



34872
62x60x75



34873
62x60x75



35057
62x60x75

SILLONES ARMCHAIRS



34874
69x70x69



34875
69x70x69

SOFÁS SOFAS



34876
90x100x82



34878
200x105x82



34877
90x100x82



34879
250x105x82

© VICALHOME 2024

Vicalhome

Pol. El Carrascot s/n · 46850 L'Olleria (Valencia) Spain

Tel. +34 962 200 060 · Fax: +34 962 208 136

vical@vicalhome.com · www.vicalhome.com

VICAL
living spaces

Gran parte del producto que ofrecemos está fabricado con maderas y acabados naturales y con procesos de fabricación artesanales, incluso en muchos casos con madera reciclada, es decir, que proviene de otro mueble. Entendemos las variaciones de tonalidad o ciertas imperfecciones en la madera como un valor añadido que convierte ese mueble en una pieza única. Recuerde consultar en la web www.vicalhome.com la disponibilidad y precio de los productos. Para consultar los precios debe dirigirse a la web. Las medidas de este catálogo están en centímetros y su formato expresa el largo por ancho por alto de cada pieza. Toda la información que aparece en este catálogo referente a dimensiones es aproximada. Las posibles diferencias entre el color original y el reproducido en este catálogo se deben al soporte del papel y al proceso de impresión. Vicalhome se reserva el derecho sobre las fotografías y diseños. Vicalhome se reserva el derecho de modificar total o parcialmente sin aviso previo cualquiera de los datos y especificaciones de esta publicación.

Most of the products are of artisan manufacturing, based on natural wooden materials, or recycled wood from other pieces of furniture. This makes each piece unique, as every one of them has a different wooden structure and colour tone. For availability and price, please check out our website www.vicalhome.com. To check the prices you must go to the web. The measures in this catalogue are expressed in centimetres and the dimensions in length, width and height of each piece. All measures are approximate. Any perceived difference between the original colour and the catalogue photo would be due to the paper and the printing process. Vicalhome has the copyright to all pictures and designs and also the right to modify the catalogue without prior notice.

VICALDESIGN

[VICALHOME.COM/ES/VICALDESIGN](https://vicalhome.com/es/vicaldesign)